

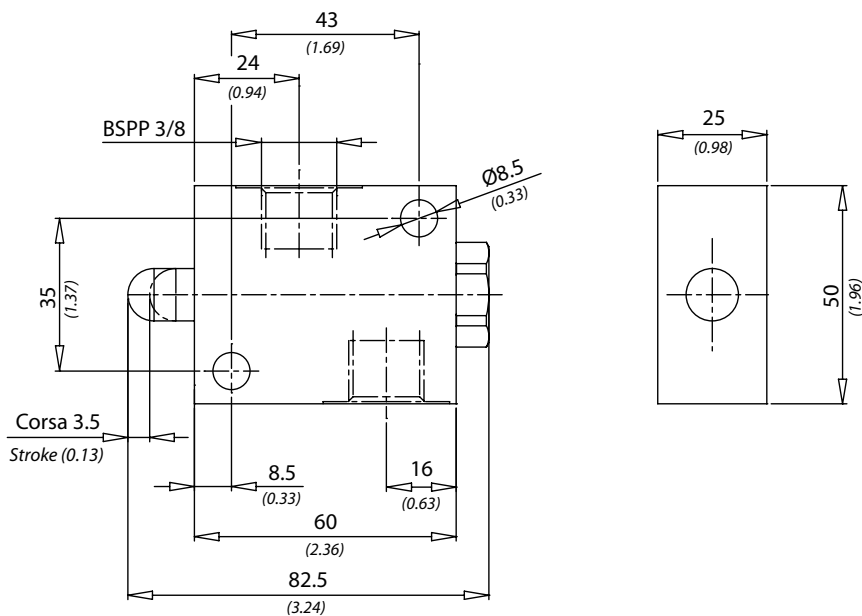

Dati tecnici Technical data	
Viscosità fluido Fluid viscosity	10-500 mm ² /s 45 to 2000 ssu (6 to 420 cSt)
Classe di contaminazione Filtration	ISO code 16/13 SAE class 4 or better
Temperatura fluido Fluid temperature	-20°C +80°C -4°F +176°F
Temperatura ambiente Ambient temperature	-20°C +50°C -4°F +122°F

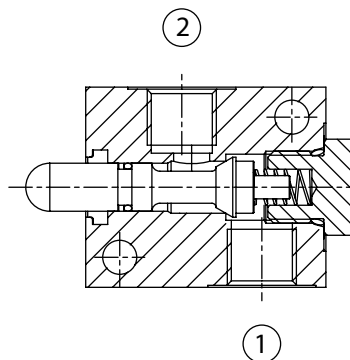

[mm
(Inches)]

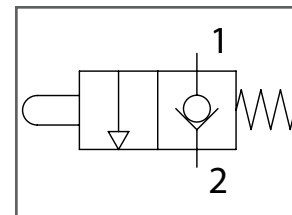
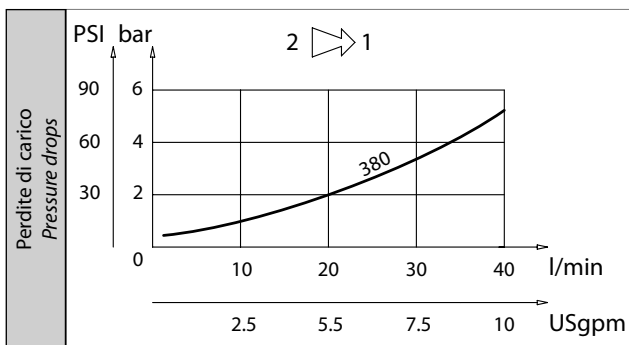

Caratteristiche tecniche Technical performances			
Codice Code	Portata Max Max flow l/min - USgpm	Pressione Max Max pressure bar/PSI	Peso approssimativo Approx weight Kg / lb
FCM380N	40 (10.5)	350 (5000)	0,50 (1.10)

Codice ordinazione Ordering code
FCM380N