

Data Sheet

EC-C1200-450

Liquid cooled heavy duty converter

FEATURES

- Extremely compact design -converter unit only 15 kg
- High enclosure class IP67 – sealed from moisture and dust
- Liquid cooled with plain water or water/glycol mixture
- Ambient temperature up to +105°C and down to -40 °C
- Allowed coolant temperature up to +65°C
- Robust design withstanding high levels of mechanical vibrations and shocks
- Designed especially for highly cyclical loads typical in heavy mobile work machines

Software features:

- 2x Isolated CAN ports supporting CANopen and SAE J-1939 protocols
- Possibility to create customer specific applications with CODESYS (IEC61131-3) software tool
- Bidirectional energy flow control
- High performance current and voltage control
- Interleaved PWM between phases for lower ripple current and voltage
- Wide selection of protective functions
- PowerUSER PC-program for commissioning and diagnostics available



GENERAL

The device is a heavy-duty converter designed especially for electric or hybrid drive trains for mobile work machines, buses or marine vessels. It can act as motor inverter, active front end, create a microgrid or as a DC/DC-converter depending on the options selected.

Typical applications:

- Boosting battery voltage to higher DC-link voltage. (+DC -option)
- Charging high voltage batteries from higher DC-link voltage. (+DC -option)
- Controlling the speed and torque of electrical traction motors (+MC -option)
- Converting alternating current (AC) from electrical generator to direct current (DC) for energy storage (+MC -option)
- Active Front End for connecting to AC grid with regenerative power and low harmonic. (+AFE -option)
- Microgrid (+UG -option)

+DC -option requires an external inductance unit. See Danfoss EC-LTS data sheets for more information. (Contact Danfoss Mobile Electrification)

+AFE and +UG -option requires an external LCL-filter unit. See Danfoss EC-LCL1200 data sheets for more information. (Contact Danfoss Mobile Electrification)

SPECIFICATIONS

DC connection (+DC -option)		Coolant volume	300 cm ³
HV-side voltage range	0-850 V _{DC}	Pressure loss	100 mbar with 10l/min (+25°C coolant)
HV-side nominal voltage	750 V _{DC}	Cooling liquid temperature	-40°C ... +65°C (with derating 1%/1°C max. +75°C)
HV-side nominal current	350 A	Ambient Conditions	
LV-side typical voltage	75-750 V _{DC} (maximum transformation ratio between LV and HV voltages is 1:10)	Storage temperature	-40°C...105°C
LV-side nominal current	See table 1.	Operating temperature	-40°C...105°C (with nominal coolant temp.)
Nominal power	See table 1. (output power is limited by the LV-side voltage and current.)	Altitude	max. 2000 m
HV-side voltage range	0-850 V _{DC}	Relative humidity	100 %
Switching frequency	8 kHz	Enclosure class	IP67
DC connection (+MC/+AFE/+UG -option)		Mechanical vibration	10 G ISO 16750-3 Test VII – Commercial vehicle, sprung masses – Table 12 Notes: test duration 8h axis (two axes tested; radial and axial) total spectral acceleration 5,91 grms
DC link voltage range	0-850 VDC	Mechanical shock	50 G ISO 16750-3 4.2.2 Test for devices on rigid points on the body and on the frame Notes: –acceleration: 500 m/s ² ; –duration: 6 ms; –number of shocks: 10 per test direction.
DC link nominal voltage	750 VDC	Connections	
AC connection (+MC/+AFE/+UG -option)		Coolant connection	2 x 20mm coolant hose connector
AC output voltage	0-560 V _{EFF} (U _{DC} = 800 V _{DC})	HV cable recommended type	HUBER+SUHNER Radox Elastomer S screened automotive cable www.hubersuhner.com
Maximum power	300 kW (500 V _{AC} , 350 A _{RMS})	HV cable cross section	≤70 mm ² (Cu)
Output frequency	0...580 Hz (Up to 1000 Hz as option)	HV cable glands (with +CG1 option)	Pflitsch blueglobe TRI bg 225ms tri
Switching frequency	8 kHz	HV cable glands (with +CE2 option)	Pflitsch blueglobe TRI bg 232ms tri
Control voltage input		HV cable lug size	35-8, 50-8, 70-8
Voltage range	7-33 V _{DC}	Recommended cable lug	50mm ² : Druseidt part no. 10853 70mm ² : Druseidt part no. 10857 www.druseidt.de
Power	14.4 W	LV connector	35-pin Tyco electronics AMPSEAL connector www.tycoelectronics.com
Current	0.6 A @ 24 V _{DC} 1.2 A @ 12 V _{DC}	LV connector type	part no. 776163-1
Mechanical			
Dimensions (WxHxL, mm)	244x109x482		
Weight	15 kg		
Cooling			
Cooling liquid	Plain water with appropriate corrosive inhibitor (max. 50 % corrosive inhibitor)		
Cooling liquid glycol type	Ethylene glycol (Glystantin G48 recommended)		
Minimum cooling liquid flow	10 l/min		
Maximum continuous pressure	2 bar		

LV mating connector type	TE 776164-1		used to improve efficiency of the motor
LV mating connector pin type	0.5-1.25 mm ² : TE 770854-3 (Gold plated)	User application	
LV connector pin configuration	see table below	IEC61131-3 environment	CODESYS V3
CAN connections	2x isolated and unterminated CAN channels	Protections	
CAN protocols	SAE J-1939 CANopen	HW overcurrent trip	750 A _{peak}
User configurable IO/analog output	5x isolated IO/analog output controllable with CODESYS applications	HW overvoltage trip	1050 V _{DC}
DCDC control characteristics (+DC -option)		SW overcurrent trip	programmable level
Converter topology	Bidirectional (Buck or Boost)	SW overvoltage trip	programmable level
Control principle	Current control Voltage control Power control	Short circuit protection	yes
Motor control characteristics (+MC -option)		High-Voltage interlock loop	HV loop on signal connector for external monitoring, HV loop pins are connected on the inverter side
Controllable motor types	Synchronous permanent magnet motors Asynchronous induction motors Danfoss synchronous reluctance assisted permanent magnet motors (SRPM)	Inverter temperature protection	Sophisticated thermal model that can lower the current if needed
Control principle	Rotor flux oriented current vector control	Inverter temperature trip	yes
Control methods	Torque reference motor control Speed reference motor control DC-link voltage control	External temperature measurement	yes, programmable warning, fault and trip levels
Field weakening control	Maximizes the field weakening performance by optimizing the use of inverter current and torque production capability of the motor	Standards and classifications	
Working point optimization	Maximum torque per ampere working point optimization is	Pollution degree class 2	
		IEC 60664-1 Overvoltage category III	
		Immunity: IEC 61800-3 Sec.5.2, UNECE R10	
		Emissions: IEC 61800-3 Sec.6 (radiated), UNECE R10	

POWER AND CURRENT VARIANTS

Basic product type	Nominal power [kW]	Nominal current [A _{DC}]	Conditions
EC-C1200-450-L+DC150	90	150	LV-side voltage 600 V _{DC} , HV-side voltage 750 V _{DC}
EC-C1200-450-L+DC250	150	250	LV-side voltage 600 V _{DC} , HV-side voltage 750 V _{DC}
EC-C1200-450-L+DC300	180	300	LV-side voltage 600 V _{DC} , HV-side voltage 750 V _{DC}
EC-C1200-450-L+DC400	240	400	LV-side voltage 600 V _{DC} , HV-side voltage 750 V _{DC}

Table 1 Device current and power ratings for +DC -option. "-S" and "-L" versions have same ratings, see topic "SMALL/LARGE SYSTEM DIFFERENCES"

Basic product type	Nominal power [kVA]	Nominal current [A _{AVG}]
EC-C1200-450-L+MC70+AFE70+UG70	50	70
EC-C1200-450-L+MC120+AFE120+UG120	100	120
EC-C1200-450-L+MC180+AFE180+UG180	150	180
EC-C1200-450-L+MC240+AFE240+UG240	200	240
EC-C1200-450-L+MC300+AFE300+UG300	250	300
EC-C1200-450-L+MC350+AFE350+UG350	300	350

Table 2 Device current and power ratings for +MC, +AFE and +UG -options. "-S" and "-L" versions have same ratings, see topic "SMALL/LARGE SYSTEM DIFFERENCES"

PRESSURE LOSS VS COOLANT FLOW

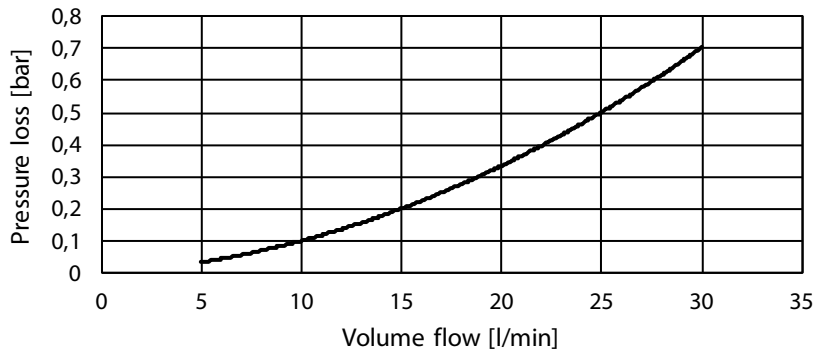

Picture 1 Device pressure loss vs coolant flow

DIMENSIONS

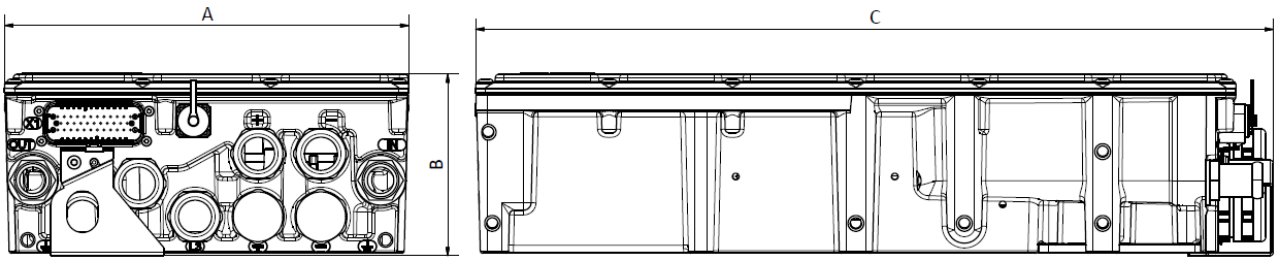

Picture 2 Device dimensions

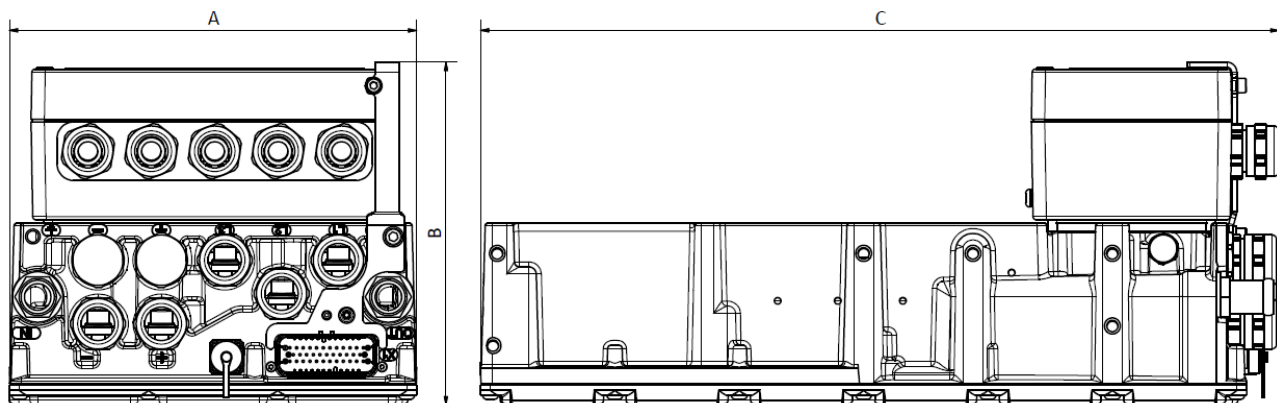

Picture 3 Device dimensions with +CE1 or +CE2 option

Dimension	EC-C1200-450 Dimensions	EC-C1200-450 with +CE1 or +CE2 option
A	244 mm	244 mm
B	109 mm	205 mm
C	482 mm	479 mm

SMALL/LARGE SYSTEM DIFFERENCES

Device has option for small systems (-S) and large systems (-L). Small system option is typical for vehicle applications and large system option is standard in marine applications because of the marine regulations. Complete system should be looked when choosing the option as for example vehicle system with many devices could also need the L-option to keep the isolation resistance or Y-capacitors at reasonable level. In large and small system options, there are difference in the isolation measurement resistance, DC-link discharge resistor and Y-capacitor values as shown in Picture 5 and Table 3.

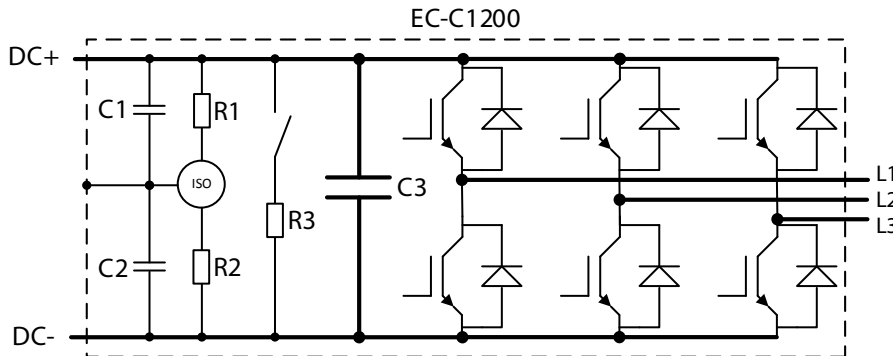

Picture 4 EC-C1200-450 internal schematic

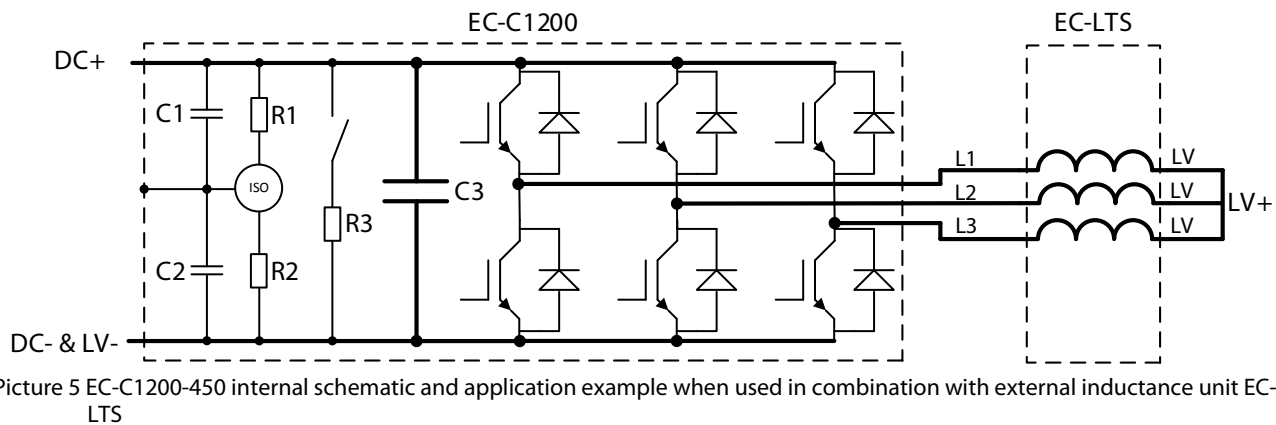

Picture 5 EC-C1200-450 internal schematic and application example when used in combination with external inductance unit EC-LTS

Component	Small-system option	Large-system option
Isolation measurement R1, R2	12 MΩ	240 MΩ
Discharge resistor R3	3.9 kΩ	39 kΩ
Y-capacitor C1, C2	330 nF	3.3 nF
DC-link capacitor C3	1 mF	1 mF
Isolation resistance from DC-link to enclosure	6 MΩ	120 MΩ

Table 3 S/L-system differences

Device with +MC, +AFE or +UG -option has internal schematic shown in Picture 4. Possible additional equipment like LCL-filter or motor is connected to the phases L1, L2 and L3. Options +AFE and +UG are not compatible with the -S version of the device. Generally, option -L is recommended for all applications.

Device with +DC -option requires external inductors to work as seen in application example shown in Picture 5. LV+ and LV- can be connected (for example) to battery and DC+ and DC- to a higher voltage DC-link. Device is in control of the discharging and charging of the battery. +DCE option is recommended when using the device in combination with the external inductance unit.

PARAMETRIZING, MONITORING AND DIAGNOSTIC OF THE DEVICE

PowerUSER monitoring and diagnostics software uses service connector on the device and PSSC service cable for connecting to the device. The PSSC is isolated RS485 and shielded cable specially designed to the demanding environments where the inverters are used, and it is available in 3 meter (PSSC-3M) and 10 meter version (PSSC-10M). The service cable is ordered separately.

Product code	Cable length	Description
PSSC-3M	3 meters	USB to RS485 isolated service cable
PSSC-10M	10 meters	USB to RS485 isolated service cable

Table 4 Service cables; ordered separately, needed for parametrizing, monitoring and diagnostics

SIGNAL CONNECTOR PINOUT

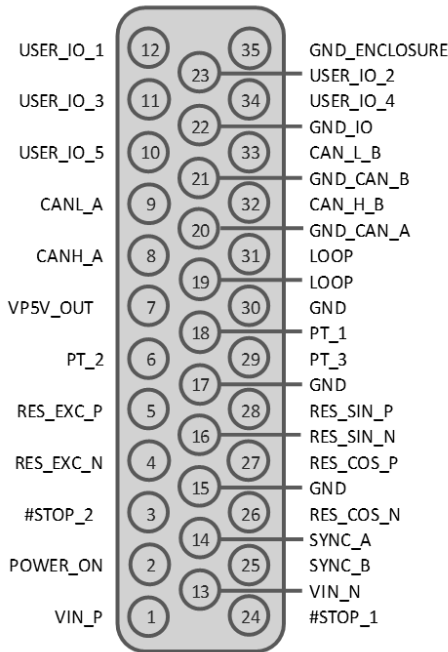

Pin number	Signal name	RevR/S/T	Comments
1	VIN_P		Positive Power Supply (7-33V)
2	POWER_ON		Active High, Turn ON @ >7.4V, Turn OFF @ < 5.8V
3	#STOP_2		Active Low, STOP @ < 1.2V, RUN @ > 4.65V Pulling one #STOP down stops the inverter
4	RES_EXC_N		Resolver excitation, use twisted pair and shield
5	RES_EXC_P		Resolver excitation, use twisted pair and shield
6	PT_2		PT100 or PT1000 temperature sensor input Connect sensor against signal GND
7	VP5V_OUT		+5V/200mA output for external sensors. Software control
8	CANH_A		CAN bus A, isolated (Functional isolation <100 VDC)
9	CANL_A		CAN bus A, isolated (Functional isolation <100 VDC)
10	USER_IO_5		Digital input ('1' @ 3V, '0' @ 2V) (max. 10 mA) Digital output ('1' = 4.8V, '0' = 0V) (max. 10 mA) Digital output open collector (max. 80mA)
11	USER_IO_3		Digital input ('1' @ 3V, '0' @ 2V) (max. 10 mA) Digital output ('1' = 4.8V, '0' = 0V) (max. 10 mA) Digital output open collector (max. 80 mA) Analog input (0-32V) (input impedance ~100 kOhm)
12	USER_IO_1		Digital input ('1' @ 3V, '0' @ 2V) (max. 10 mA) Digital output ('1' = 4.8V, '0' = 0V) (max. 10 mA) Digital output open collector (max. 80 mA) Analog input (0-32V) (input impedance ~100 kOhm)
13	VIN_N		Negative Power Supply (0V)
14	SYNC_A		SYNC_A for Master/Slave
15	GND		Signal GND / PT100 or PT1000 GND
16	RES_SIN_N		Resolver input, use twisted pair and shield
17	GND		Signal GND / PT100 or PT1000 GND
18	PT_1		PT100 or PT1000 temperature sensor input Connect sensor against signal GND
19	LOOP		High Voltage Diagnostic Loop
20	GND_CAN_A		GND for CAN bus A
21	GND_CAN_B		GND for CAN bus B
22	GND_IO		GND for IO, IO is isolated (Functional isolation <100 VDC)
23	USER_IO_2		Digital input ('1' @ 3V, '0' @ 2V) (max. 10 mA) Digital output ('1' = 4.8V, '0' = 0V) (max. 10 mA) Digital output open collector (max. 80 mA) Analog input (0-32V) (input impedance ~100 kOhm)
24	#STOP_1		Active Low, STOP @ < 1.2V, RUN @ > 4.65V Pulling one #STOP down stops the inverter
25	SYNC_B		SYNC_B for Master/Slave
26	RES_COS_N		Resolver input, use twisted pair and shield
27	RES_COS_P		Resolver input, use twisted pair and shield
28	RES_SIN_P		Resolver input, use twisted pair and shield
29	PT_3		PT100 or PT1000 temperature sensor input Connect sensor against signal GND
30	GND		Signal GND / PT100 or PT1000 GND
31	LOOP		High Voltage Diagnostic Loop
32	CAN_H_B		CAN bus B, isolated (Functional isolation <100 VDC)
33	CAN_L_B		CAN bus B, isolated (Functional isolation <100 VDC)
34	USER_IO_4		Digital input ('1' @ 3V, '0' @ 2V) (max. 10 mA) Digital output ('1' = 4.8V, '0' = 0V) (max. 10 mA) Digital output open collector (max. 80 mA) Analog input (0-32V) (input impedance ~100 kOhm)
35	GND_ENCLOSURE		Enclosure ground

PRODUCT CODE AND OPTIONS

Use product code including all needed options for ordering. Standard options do not need to be listed in the code as they are selected by default if a non-standard option is not selected. Device requires external inductors to work. Separate inductor unit can be ordered with product name EC-LTS1200-400.

Options +MC, +AFE and +UG can be selected to the same unit at same time if necessary. +DC option can only be selected alone without other control options.

Options +AFE and +UG are not compatible with the option -S. **Generally, option -L is recommended for all applications.**

Product code	Description
EC-C1200-450-L+MC300	L-version unit for controlling motor with 300 A current limit
EC-C1200-450-L+MC300+CG1	L-version unit for controlling motor with cable glands and 300 A current limit
EC-C1200-450-S+DC400+DCE	S-version unit for DCDC applications with double DC-connections and 400 ADC current limit

Table 5 Product code examples

				s = standard
				o = option
Variant	Code	Description		
System size	-S	Small system	o	Default EC-C unit for individual or small system installations
	-L	Large system	o	EC-C unit for large system installations
Control	+MC70	Motor control, current limit 70 A	o	Converter for motor/generator applications
	+MC120	Motor control, current limit 120 A	o	Converter for motor/generator applications
	+MC180	Motor control, current limit 180 A	o	Converter for motor/generator applications
	+MC240	Motor control, current limit 240 A	o	Converter for motor/generator applications
	+MC300	Motor control, current limit 300 A	o	Converter for motor/generator applications
	+MC350	Motor control, current limit 350 A	o	Converter for motor/generator applications
	+AFE70	Active front end, current limit 70 A	o	Converter for active front end applications
	+AFE120	Active front end, current limit 120 A	o	Converter for active front end applications
	+AFE180	Active front end, current limit 180 A	o	Converter for active front end applications
	+AFE240	Active front end, current limit 240 A	o	Converter for active front end applications
	+AFE300	Active front end, current limit 300 A	o	Converter for active front end applications
	+AFE350	Active front end, current limit 350 A	o	Converter for active front end applications
	+UG70	Microgrid, current limit 70 A	o	Converter for microgrid applications
	+UG120	Microgrid, current limit 120 A	o	Converter for microgrid applications
	+UG180	Microgrid, current limit 180 A	o	Converter for microgrid applications
	+UG240	Microgrid, current limit 240 A	o	Converter for microgrid applications
	+UG300	Microgrid, current limit 300 A	o	Converter for microgrid applications
	+UG350	Microgrid, current limit 350 A	o	Converter for microgrid applications
+DC150	DCDC control, current limit 150 ADC	o	Converter for DC/DC applications	
+DC250	DCDC control, current limit 250 ADC	o	Converter for DC/DC applications	
+DC300	DCDC control, current limit 300 ADC	o	Converter for DC/DC applications	
+DC400	DCDC control, current limit 400 ADC	o	Converter for DC/DC applications	
Speed option	*	Normal speed version (<580Hz output frequency)	s	EC-C with motor/generator control firmware, capable of speeds below 580 Hz.
	+HS	High speed version (>580 Hz output frequency)	o	EC-C with motor/generator control firmware, capable of speeds up to 1000 Hz.
Communication	*	CAN1939	s	EC-C with Standard SAE1939-communication
	+CO	CANopen	o	EC-C with CANopen-communication
Connections	*	Normal connections	s	EC-C with default HV connections
	+CE1	Connection extension 1	o	EC-C with double DC and AC connectivity with connection extension box 1 (double M25 cable gland threads)(Not compatible with +DCE option)
	+CE2	Connection extension 2	o	EC-C with M32 cable gland threads on AC connection with connection extension box 2 (choose also +DCE if double DC connection is required)
	+DCE	DC-extension	o	EC-C with double DC-connections: copper bushings for double connection (compatible with +CE2/+CG4/+CG5)
Glands	*	No glands	s	EC-C with no cable glands or plugs
	+CG1	Default M25 cable glands	o	EC-C with 5x M25 cable glands and 2x M25 plugs
	+CG2	Default M25/M32 cable glands	o	EC-C with 2x M25 cable glands, 3xM32 cable glands and 3xM25 plugs (for +CE2 option)
	+CG3	Default M25 cable glands	o	EC-C with 10x M25 cable glands (for +CE1 option with double DC-link connections)
	+CG4	Default M25 cable glands	o	EC-C with 7x M25 cable glands (for +DCE option)
	+CG5	Default M25/M32 cable glands	o	EC-C with 4x M25 cable glands, 3xM32 cable glands and 3xM25 plugs (for combined +CE2 and +DCE options)
	+CG6	Default M25 cable glands	o	EC-C with 8x M25 cable glands and 2x M25 plugs (for +CE1 option with single DC-link connections)
Customer specific	*	Default unit firmware-wise	s	EC-C with no pre-set parameters or application
	+CS	Customer specific parameters or application in FW	o	EC-C with separately specified application and/or parameters

Table 6 Option list

NOTE! Products delivered with high speed option (+HS) are subject to export control as dual-use items when transported outside of European community according to CE 428/2009 regulation.

Danfoss can accept no responsibility for possible errors in catalogues, brochures and other printed material. Danfoss reserves the right to alter its products without notice. This also applies to products already on order provided that such alterations can be made without changes being necessary in specifications already agreed. All trademarks in this material are property of the respective companies. Danfoss and the Danfoss logotype are trademarks of Danfoss A/S. All rights reserved.