

Ordering code	01	02	
	FCM	120N	
01	<i>Normally closed end - stroke valves</i>		FCM
02	<i>Size</i>	BSPP 1/2	120N

Hydraulic circuit

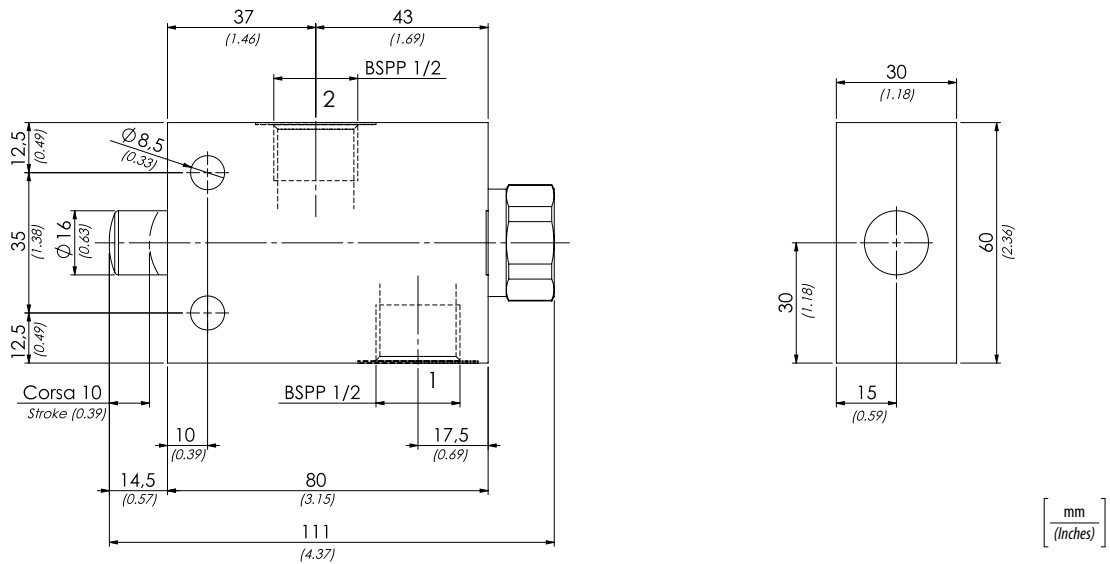

Performances

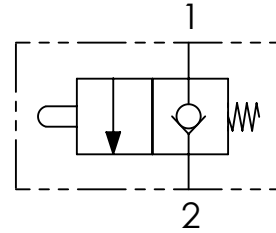
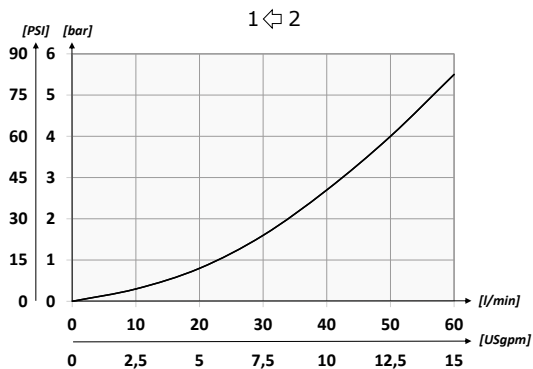

Technical data

Mineral oil	ISO 6743/4 (DIN 51524)
Oil viscosity	15-250 mm²/s (15 to 250 cSt)
Max contamination index with filter	ISO 4406:1999 Classe 19/17/14
Oil temperature	-20°C +80°C -4°F + 176°F
Ambient temperature	-20°C +50°C -4°F + 122°F

It is necessary a filter use to protect the valve (advised filtration 15 µm)

Technical characteristics

Type	Max flow l/min-USgpm	Max pressure (PSI)	Approx weight kg-lb
FCM120N	60 (15.8)	300 (4350)	1,01 (2.22)